

A5 (T)
 A5 (TD)
 Rotary Screw
 Air Compressor
 Units
 - - -
 Installation
 And
 Service Data

Contents:	Page:
Quick Start	2
Safety Precautions	4
Unpacking and Inspection	5
Installation – Mechanical	6
Lubrication	8
Installation – Electrical	9
Start-up Procedures	11
Preventative Maintenance Schedule	12
Common Compressor Faults	14
Separator Filter and Refrigerated Air Dryer.....	15
Troubleshooting Guide	18
Warranty	21



Please read this manual before installing or using your Air Compressor Unit. It contains valuable information that will help in the receiving, installation, use, and maintenance of the Unit.

Please keep this manual in a safe place for future reference.

All of the information, policies, and procedures in this reference manual apply exclusively to DV Systems.

If you require assistance, please contact your local DV Systems Distributor or Authorized Service center. You may contact the manufacturer directly as follows:

Phone:	(705) 728-5657 (Canada) (704) 799-0046 (USA)	Web:	www.dvcompressors.com
Fax:	(705) 728-4974 (Canada) (704) 799-0355 (USA)	Email:	sales@dvcompressors.com (Canada) orders@dvcompressors.com (USA)

Quick Start

Mechanical Installation.

(Refer to Page 6)

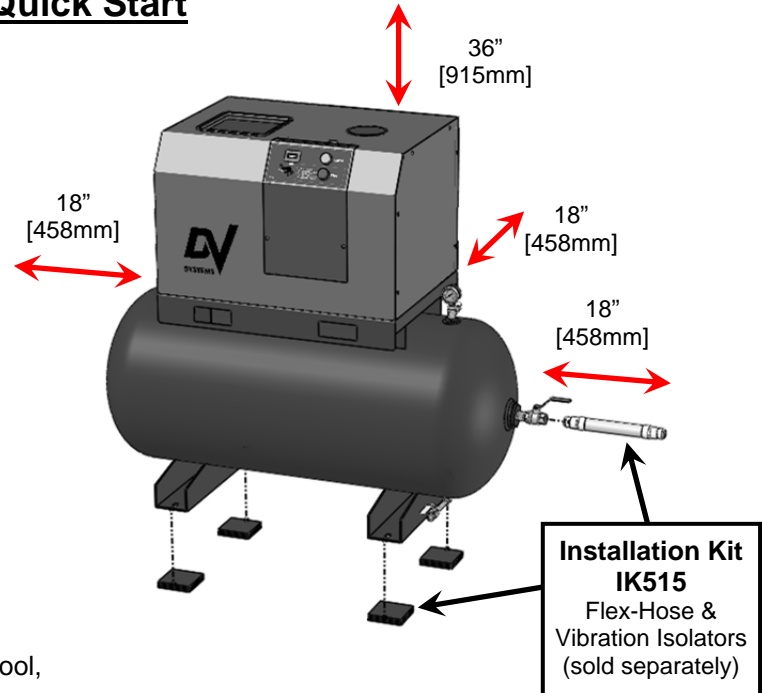
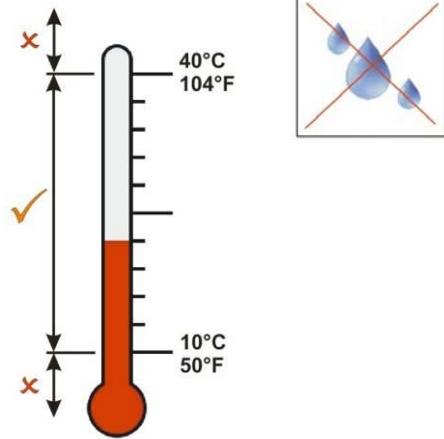

- The Unit should be located in a dry, clean, cool, dust free, and well ventilated area.
- Allow a minimum 18" (458mm) around and 36" (915mm) above Unit.
- The ambient temperature should be between 10°C and 40°C (50°F and 104°F).
- Ensure that the floor under the Unit is smooth, level and capable of bearing the weight of the Compressor.
- If installed in a compressor room, ensure that the room is adequately ventilated

CAUTION

**Drain condensate (water) from oil tank.
If compressor work-cycle experiences long
pauses, condensate will gather in oil tank.
Drain condensate EVERY 50HRS OR WEEKLY.
(Refer to Page 8 for details)**

Lubrication.

(Refer to Page 8)

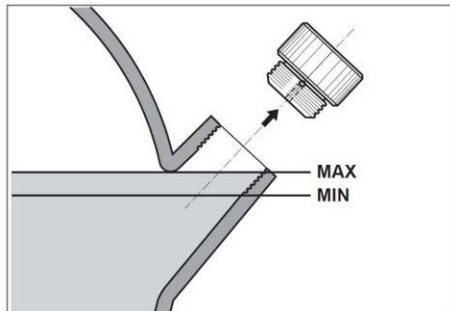

- Ensure the oil level in the Air End is between the top (maximum) or bottom (minimum) thread as shown.

Rotation.

(Refer to Page 10)

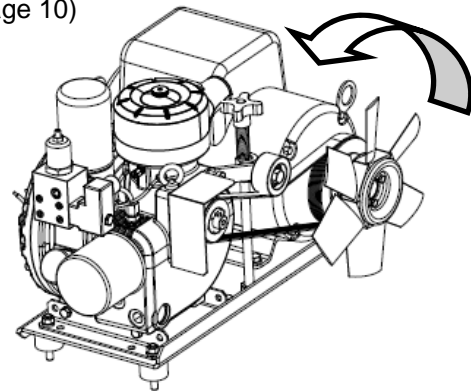

- The correct rotation is as shown.
- The Unit is equipped with an Anti-Rotation Switch. Check that the rotation is correct.

Quick Start (cont'd)

Unit Operation.

Shown below is the 'CSC15' Controller which regulates the operation of the Unit. Unit Status LEDs, Hour Meter, and ON/OFF switch are located on the control panel cover.

Starting the Unit: Turn the Selector Switch to '**ON**' position.

Stopping the Unit: Turn the Switch to '**OFF**' position, unit will unload for 10 seconds prior to stopping.

Note:

1. Do not stop the Unit by use of a disconnect or breaker.



Using the disconnect, or breaker to stop the Unit will not allow the Unit to go through an unloading sequence, and could result in damage to the Motor, Starter, or other electrical components. Damage caused in this manner is not covered by the manufacturers Warranty.

Hour Meter.

Displays the number of running hours.

Power Light.

Turns on when power has been applied to the unit.



Start / Stop Switch

ON position:
Starts compressor
OFF position:
Compressor unloads for 10 seconds and then stops

Fault Light.

Compressor fault indicator:
ON Solid = Anti-Rotation
Fast Flash = Power Interruption
Slow Flash = Service Due*
Two Flashes = High Temp Fault
Three Flashes = Overload Fault
*Depress 'Reset' button within cabinet to clear fault.







Safety Precautions

In order to operate the Compressor Unit safely and correctly, we have opted to use the following symbols to make you aware of important points. These points relate to user safety and preventing equipment problems. Please pay close attention to these sections.

<div style="text-align: center; background-color: black; color: white; padding: 5px; border-radius: 10px; margin-bottom: 10px;"> WARNING </div> <p>Important safety Information. A hazard that may cause serious injury or loss of life.</p>	<div style="text-align: center; background-color: black; color: white; padding: 5px; border-radius: 10px; margin-bottom: 10px;"> CAUTION </div> <p>Important information that indicates how to prevent damage to equipment, or how to avoid a situation that may cause minor injury.</p>	<div style="text-align: center; background-color: black; color: white; padding: 5px; border-radius: 10px; margin-bottom: 10px;"> NOTE </div> <p>Information that you should pay special attention to.</p>
--	--	---

WARNING

The following hazards may occur during the normal use of the equipment. Please read the following chart.

<u>Area:</u>	<u>Hazard:</u>	<u>Safeguards:</u>
What to look for.	What may occur if precautions are not observed.	How to avoid the hazard.
	Tampering with the Unit while under full or partial pressure may cause an explosion.	Relieve all pressure from the Unit before attempting any repair or maintenance work.
	As the Unit starts and stops automatically, serious injury may result from working on the Compressor with the power still in the 'on' position.	Shut off all power to the Unit before attempting to repair or maintain the Compressor.
	As the Unit starts and stops automatically, do not come into contact with moving parts.	Shut off all power to the Unit before attempting to repair or maintain the Compressor.
	Air compressed by the Unit is not suitable for inhaling. It may contain vapours harmful to your health.	Never breath untreated compressed air produced by the Compressor.
	Compressor Air End, Motor, and Tubing become hot when running. Touching these areas may cause serious burns.	Never touch the Air End, Motor, or Tubing during or immediately after operation.
	As the electrical components on the Compressor are General Purpose, there is a potential for explosion, should vapours be present in the area.	Do not install in hazardous locations. The Compressor must be a minimum of 20 feet (6.1 meters) from any source of potentially explosive vapours.

Unpacking and Inspection

NOTE

Each DV Systems Air Compressor is carefully tested and inspected before shipment. Though every attempt is made to ensure the safe and complete shipment of our product, freight damage or misplacement of goods may occur.

Shipments of DV Systems products are the property of the Consignee when the products leave our facility. DV Systems Inc. is not responsible for any damages or shortages caused to the product after it has left our shipping dock.

It is the responsibility of the receiver of the goods, either the Distributor or Customer, to ensure that the product has been shipped in full, and has arrived in suitable condition. Damage to the product may not be visible at time of off-loading, but may only become apparent upon unpacking or start-up.

Some areas to initially check are as follows:

- a) Check for damage to the crating and/or packaging.
- b) Check the exterior of the Cabinet for damage, either cosmetic or mechanical.
- c) If there is mechanical damage, open the Cabinet to determine whether there is any internal damage to the Unit.

Should there be damage to the product or shortages in shipment:

- 1) Stop any further unpacking or operation of the product.
- 2) Make note of the problem on the Freight Bill, should it concern a shortage or visible damage to the product.
- 3) Should the damage be noticed only after the product has been received, contact the transport company immediately to file a claim.
Depending on the problem, it may be wise to photograph the damage. Also, it may be wise to discuss with the carrier representative the time allotted to give notice of loss or damage to the product; there may be guidelines which limit timeframes of same.
- 4) Do not attempt further unpacking or operation of the product. Also, do not discard any packing material used.
- 5) A Loss or Damage Claim must be submitted to the carrier and supported by the following documents:
 - Copy of Freight Bill of Lading
 - Copy of the Invoice and Estimate to repair, in case of damage
 - Damage Report
 - Copy of photos, if applicable

Installation – Mechanical

Moving of the Unit.

When moving the Air Compressor, the forklift or hand lift forks go under the Unit from the directions as indicated.

Please be advised that care must be taken when moving and positioning the Units as they are top heavy.

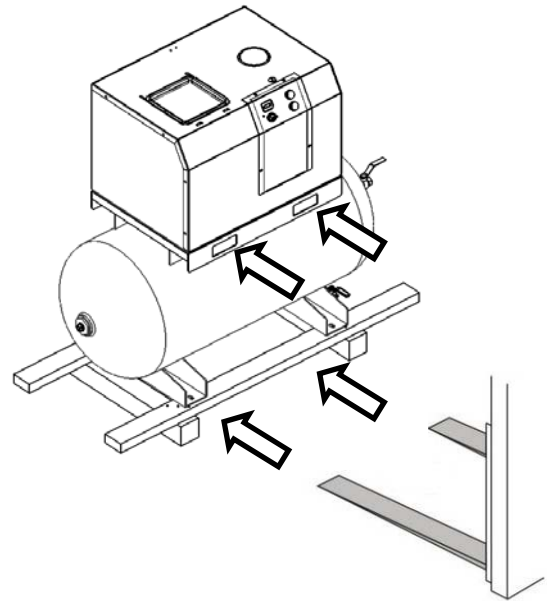

Location of the Unit.

Items to consider when installing the Unit are as follows:

- The Unit should be located in a dry, clean, cool, dust free, and well ventilated area. If possible, the Compressor should be located in a separate room or area, away from the general operations of the shop.
- Allow approximately a minimum of 18" (458mm) around and 3 feet (915mm) above the Unit for easy access to the various sides, this being for both the proper ventilation of the Unit and ease of servicing.
- Ensure that the floor under the Unit is smooth, level and capable of bearing the weight of the Compressor. The Compressor must sit squarely on the floor.
- If installed in a compressor room, ensure that the room is adequately ventilated. (One Horsepower produces approximately 2500 BTU/HR.)
- The ambient temperature should be between 10°C and 40°C (50°F to 104°F).

- If installing the Unit on a mezzanine, ensure that the structure can safely support the weight of the Unit. As well, the sound level of the Unit may increase due to the harmonics created by the structure; use Vibration Pads to lessen this.

Many common Compressor problems can be attributed to the location or installation of the Unit. Make sure the Unit is in a suitable location, and installed correctly.



The Compressor must not be operated in a confined area where the heat from the Unit cannot readily escape.

Installation – Mechanical (cont'd)

Shown below are items which assist in making a good installation. These are both intake and exhaust ductwork, helping the Unit to a) draw in clean outside air and b) exhaust the warmer air away from the Unit. The warmer air may be used, with the inclusion of a damper in the exhaust ducting, to warm the interior of the building during the colder months of the year.

TYPICAL DUCTING INSTALLATION LAYOUT

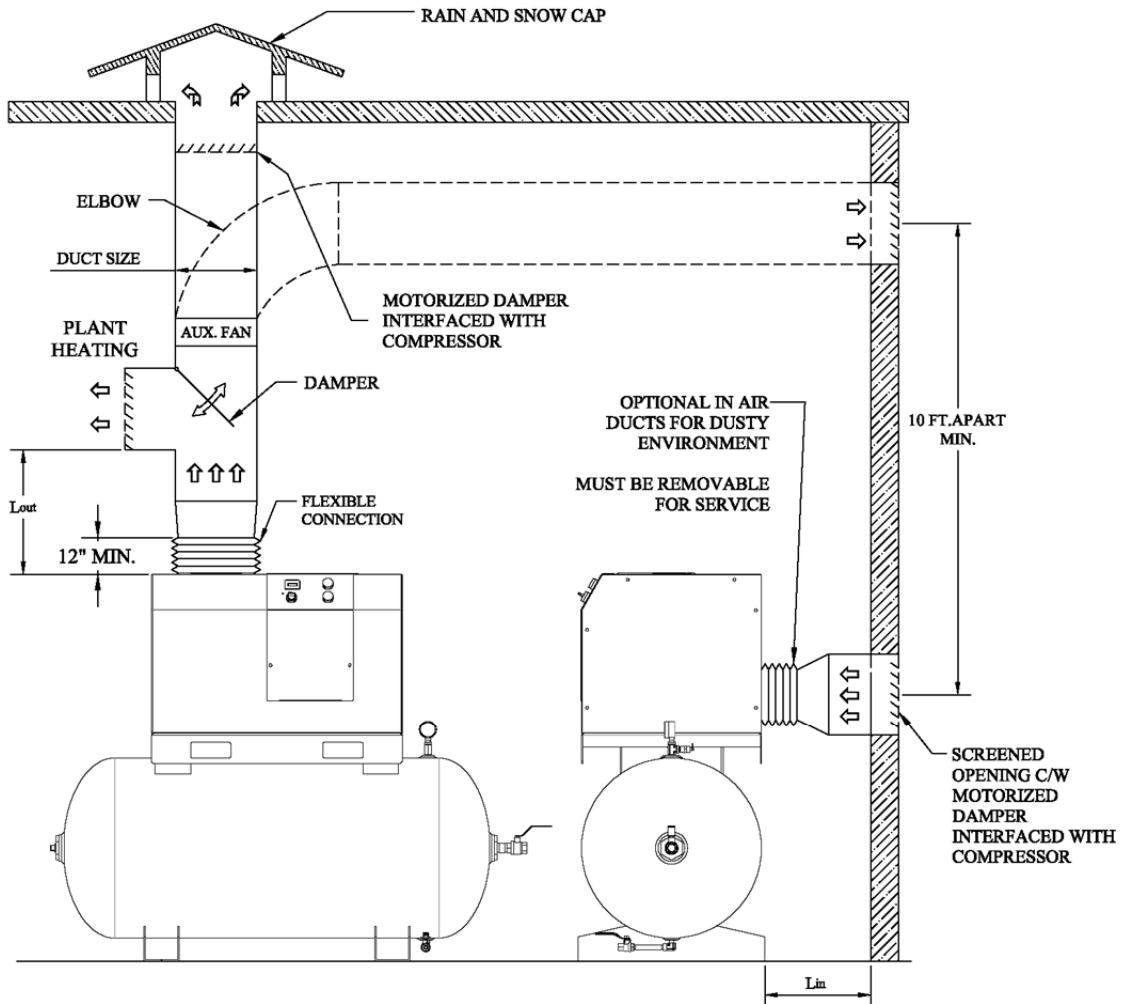

MODEL	HP	HEAT LOAD (BTU/HOUR)	COOLING AIR (CFM)	RECOMMEND MIN. DUCT SIZE	MAX. DUCT LENGTH <i>Lin, Lout</i>	AIR OUT OPENING AT COMPRESSOR
A5	5	12,505	450	Ø 12" (CIRL.) 12" x 12" (RECT.)	3 Ft. (Aux. Fan required if >3ft.)	OUTLET SIZE 7 7/8" x 7 7/8" INLET SIZE 10 1/2" DIA.

NOTE:

1. DUCTING SIZE BASED ON GALVANIZED STEEL DUCTS.
2. MAXIMUM PRESSURE DROP DUE TO DUCTING SYSTEM SHOULD BE WITHIN 0.1 IN. OF WATER.
3. ADDITIONAL VENTILATION SYSTEM NEEDED FOR PRESSURE DROP EXCEED ABOVE LIMIT.
4. OPERATION TEMPERATURE: MIN. 10°C (50°F) ~ MAX. 40°C (104°F).
5. ANY DEVIATION FROM ABOVE INSTALLATION, CONSULT DV SYSTEMS TECHNICAL SUPPORT.

Lubrication

Initial Start-up.

Each Compressor Unit built is extensively tested at the factory before shipment. The Unit is shipped with the original oil in it as used for testing purposes.

Check the Oil level and for any Oil leaks on a daily basis. This must be done when the Unit is off. Top up the Oil level on a monthly basis.

Use only DV Systems 'DEV-3000' Synthetic Oil.

Subsequent Oil Changes.

Drain the existing oil from the Unit. (Please be advised that the Unit cannot be drained fully of oil, as some oil may remain in various components ie Cooler, Tubing, etc.)

Fill the Oil Reservoir to the top of the Oil Fill Port as shown below. Do not under or overfill. See drawing below.

Use only DV Systems 'DEV-3000' Synthetic Oil, available in both 1 US gallon (3.8 litre) jugs or 5 US gallon (5 x 3.8 litre) pails. Any remaining oil may be used for 'top-ups'.

The 'MK-A5' Maintenance Kit includes:

- (1) US Gallon (3.8 litre) Oil ('DEV-3000')
- (1) Oil Filter ('DSC-603')
- (1) Air/Oil Separator Filter ('DSC-002832')
- (2) Air Filters ('DSC-001569')

This Kit should be used in the regular servicing of your Unit.

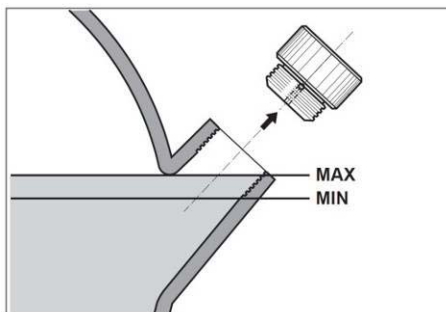

Do not attempt to operate the Unit without first checking whether there is oil in the Air End Reservoir. Add oil as required. Serious damage may result from use, however limited, without oil.



Use of improper oil may negatively affect Compressor performance or shorten Unit life. Resulting problems are not covered by the DV Systems Inc. Air Compressor Warranty.



Condensation (water) may form in the Air End if the compressor work cycle experiences long pauses. If this occurs, the condensate MUST be drained EVERY 50HRS OR WEEKLY:

- Wait for compressor to cool for approx. 2HRS.
- Remove service panel
- Slowly open the oil drain valve on the air end & drain condensate
- When the first traces of oil appear, close the cap/valve
- Top up the Air End with new oil using only DV Systems 'DEV-3000' oil.

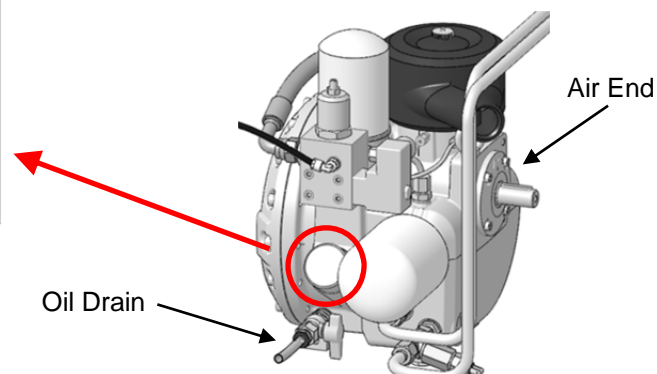

Installation - Electrical

General Information.

It is your responsibility to ensure that the Compressor Unit is electrically connected in a safe and correct manner. **Any electrical work should be carried out by a competent Electrician, and be done in such a way that it meets all applicable Codes and Regulations.**

Ensure that a suitable Fused Disconnect or Breaker (by others than DV Systems) is installed in the electrical supply before the Compressor Unit.

The sales drawing found at the back of this booklet indicates the amp rating for the Unit. This information is required in sizing a Disconnect, Fuses, and/or a suitable Breaker. As well, an electrical schematic is enclosed for reference.

Electrical wiring and conduit from the building supply, through the Compressor Cabinet, and to the Switch in the Compressor Control Panel, must be rated for 110°C (230°F) or higher.

WARNING

- **Failure to correctly connect the Compressor to your building's electrical services may result in serious personal injury or damage to the equipment.**
- **Before servicing the Unit, ensure the power source has been shut down and locked off.**
- **Install all covers and panels before applying power to the Unit.**
- **Read and understand the information contained in this manual before installing or operating the Unit.**
- **Failure to install proper fuse protection may void the unit warranty**

Failure to observe any of the above precautions could result in severe personal injury or death, and/or damage to the Unit.

Wiring Practices.

When making power and control wiring connections, please observe the following precautions:

- Ensure that all wiring, fusing, etc is done in a manner that meets with the appropriate codes and regulations.
- See the sales drawing and electrical schematic contained in this booklet for Unit amp draw, as well as Unit fuse sizes and overload settings.
- A licensed Electrician is to determine the appropriate Disconnect/Breaker and wiring sizes based on the Unit amp draw and the appropriate Electrical Code.

Fixed Speed Units:

Use TIME-DELAY type fuse.

Max. Allowable Fuse = 1.75 x Motor Full Load Amp

Installation – Electrical (cont'd)

CAUTION

Do not attempt to operate the Unit without first checking whether there is oil in the Air End Reservoir. Add oil as required. Serious damage may result from use, however limited, without oil.

Electrical Connection.

The Electrician is to bring power to the Unit through the 3/4" conduit hole located on the top of the unit. The Electrical Panel is accessible by means of opening the Front Control Panel Cover.

2 terminal blocks and 1 ground lug are provided for main power hook-up.

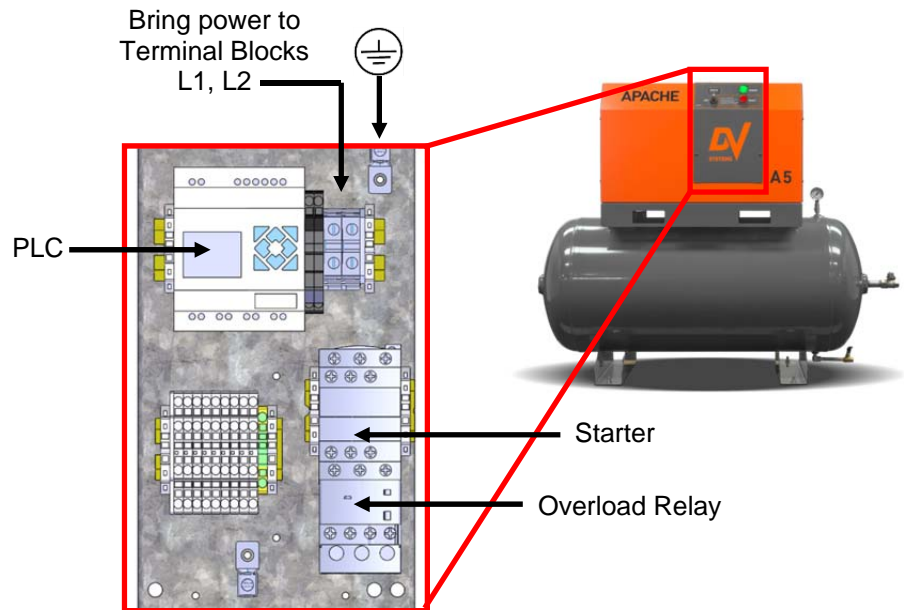

Motors.

Wiring must be done in a manner that the full Motor nameplate voltage +/- 5% is available at the Motor terminals during start-up. Contact your local Distributor or Service Centre if additional information is needed.

The Warranty that exists on the Electric Motor is that of the original manufacturer. In the event of a Motor failure, contact your DV Systems Distributor or Service Centre for the location of the nearest authorized Motor Service Centre.

Motor/Air End Rotation.

It is critical that the Motor and Air End in the Rotary Screw Unit be turning in the correct manner. Irreparable damage will be done if the Unit rotates in the opposite direction. The correct rotation is shown at right.

The Unit is equipped with an Anti-Rotation Switch. If the Unit will not start and an 'Anti Rotation' error is noted on the Controller, change the connections at the motor connection box to the following:

- Motor L#1 & Motor L#5 with Harness Black
- Motor L#4 & Motor L#8 with Harness White

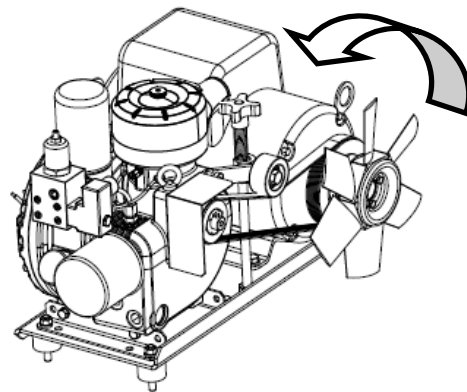

Start-up Procedures

Unit Controls

Start/Stop Switch

Start position:
allows the Unit to start.

Stop position:
unit will shutdown after 10 secs.



Initial Start-up

- 1) Remove the RH Side Access Panel, and ensure that there is sufficient Oil in the Air End. Refer to the 'Lubrication' section (page 8) in this manual for proper type and level of Oil.
 - 2) Do a visual inspection of the Unit, and ensure that no internal damage was caused during transit.
 - 3) Place the Fused Disconnect or Breaker in the 'On' Position. Check that there is power to the Controller, the green Power light will be on.
 - 4) During normal operation of the Unit, keep the Access Panels closed at all times. As well, do not place any obstructions against or on top of the Unit, thereby limiting the flow of cooling air.
 - 5) Ensure the Ball Valve on the Unit is closed, turn the Selector Switch to the 'On' position, and run the Unit up to maximum pressure. The Unit will run up to 145 psi (10bar), at which point the Motor will continue to run but not compress air.
- 6) Once the Unit reaches 145 psi (10bar), it will idle for 1 minute and shut off.

Default Offload Time of this unit is 1 minute. It would switch from 1 minute to 3 minutes if rate of pressure decay is high.
 - 7) Open the Ball Valve slightly and allow the air to bleed from the Tank. Once the pressure reaches approx. 110 psi (7.6bar), the Unit will start and begin to compress air after a short delay.
 - 8) Measure the amp draw when the Unit reaches the maximum pressure of 145 psi (10bar).
 - 9) Close the Ball Valve, allow the Unit to reach maximum pressure, idle, and shut off.
 - 10) The Unit is ready for normal use.
 - 11) Register the Unit to Activate the Warranty at:

www.dvcompressors.com/product-registration/

CAUTION

Do not place any materials in close proximity to the Compressor. Placing materials against or close to the Unit will limit the cooling required, and could lead to premature failure.

WARNING

Shut off all power to the Air Compressor Unit before attempting any repair or maintenance.

NOTE

Adjusting the settings of the Controller could adversely affect the performance of the Unit. Only those individuals with knowledge of the Unit should make any adjustments.

Preventative Maintenance Schedule



When servicing the Air Compressor, shut off all power to the Unit, and drain it of air pressure.



It is the responsibility of the compressor owner to ensure that a regular Maintenance Schedule is followed.

Noted on the following pages are general Maintenance guidelines based on average working conditions. Should the Unit be worked under extreme conditions, please contact your DV Systems Distributor for further input. As well, all maintenance/service work must be carried out by a qualified Technician.

The typical operating temperature of the Unit, this dependant on ambient temperatures, is between 70°C and 85°C (158°F and 185°F).

If the operating temperature of the Unit is too low (less than 70°C (158°F)):

- condensation will build up in the system and mix with the oil, causing internal component problems in the Unit
- Change the ambient conditions to increase the operating temperature.

If the operating temperature of the Unit is too high (above 85°C (185°F)):

- the oil will oxidize and lose it's properties, this causing internal damage to components as well
- to combat this, the oil must be changed more often than noted below.

Note: For Compressor Units used in an environment where the ambient temperature is above 32°C (90°F), the components marked with a ' # ' (on the chart on the following page) must be changed more frequently, and not as noted below.

Regular Maintenance Items.

DV Systems offers a Maintenance Kit for your Unit, namely:

MK-A5 5 HP 'A Series' Units

Each Kit consists of the following items, these suitable for approximately 4000 hours of operation.

- | | | |
|-----|--------------------|--------------------------|
| (1) | DEV-3000-K1 | 1 Gal. of Synthetic Oil |
| (1) | DSC-603 | Oil Filter |
| (1) | DSC-002832 | Air/Oil Separator Filter |
| (2) | DSC-001569 | Air Filter |

Internal Access for Maintenance.

The internal components of the Unit are accessible for servicing by way of removing the RH Side Panel.

The Back Panel is also removable to access the Belts.

Remove the plastic cap to change air/oil separator filter.

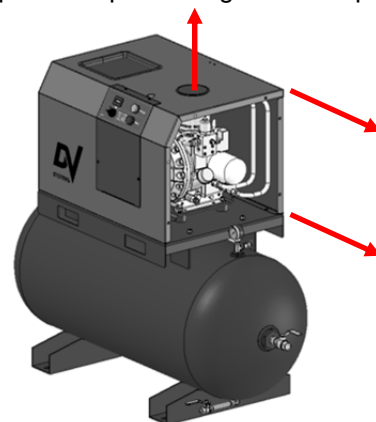



Preventative Maintenance Schedule (cont'd)

Maintenance Item:	Daily	Maintenance Interval (in 000's of Hours)																			
		2	4	6	8	10	12	14	16	18	20	22	24	26	28	30	32	34	36	38	40
Compressor Room																					
Temperature	Inspect	Ambient Temperature should be between 10°C and 40°C (50°F and 104°F)																			
Cleanliness	Inspect																				
Air Compressor Unit																					
Check Oil Level	Inspect																				
Replace Oil # (See Note b)	(1)		X		X		X		X		X		X		X		X		X		X
Replace Oil Filter #	(2)		X		X		X		X		X		X		X		X		X		X
Replace Air / Oil Separator #	(3)		X		X		X		X		X		X		X		X		X		X
Replace Air Intake Filter #	(4)	X	X	X	X	X	X	X	X	X	X	X	X	X	X	X	X	X	X	X	X
Replace Belt	(5)				X				X				X				X				X
Replace Tank Relief Valve							X						X						X		
Replace Solenoid	(6)				X				X				X				X				X
Rebuild Intake Valve	(7)				X				X				X				X				X
Rebuild Thermo Valve	(8)						X						X						X		
Rebuild Minimum Pressure Valve	(9)				X				X				X				X				X
Motor Bearing Lubrication		Refer to Motor Manufacturer's Recommendations																			

- Notes:**
- a) For Compressor Units used in an environment where the ambient temperature is above 32°C (90°F), or b) where the Unit temperature runs regularly above 80°C (175°F), the components marked with a '#' must be changed twice as often (example: in 2000 hours instead of 4000), and not as noted above.
 - b) A complete Oil change must be done every 4000 hours of Unit operation, or every 12 months, whichever occurs first. Please refer to the Warranty on Page 18 for further information.
 - c) If a component, during a regular inspection, has proven to be defective or unfit for regular operation, it must be repaired or replaced.

Parts and Repair Kits based on the above chart are as follows:

- | | | |
|-----|-----------------------------|--|
| (1) | Oil: | DEV-3000-K1 |
| (2) | Oil Filter: | DSC-603 |
| (3) | Air / Oil Separator: | DSC-002832 |
| (4) | Air Intake Filter: | DSC-001569 |
| (5) | Belt (1): | DSC-002820 |
| (6) | Solenoid with Cable: | DSC-002885 (up to AE S/N SC272839)
DSC-002957 (above AE S/N SC272839) |
| (7) | Intake Valve Repair Kit | DSC-001712 |
| (8) | Thermo Valve Repair Kit: | DSC-002057 |
| (9) | Minimum Pressure Valve Kit: | DSC-001713 |
| | Shaft Seal Kit | DSC-002835 |

As noted previously, the 'MK-A5' Maintenance Kit includes the following items:

- | | | |
|-----|--------------------|--------------------------|
| (1) | DEV-3000-K1 | 1 Gal. of Synthetic Oil |
| (1) | DSC-603 | Oil Filter |
| (1) | DSC-002832 | Air/Oil Separator Filter |
| (2) | DSC-001569 | Air Filter |

Common Compressor Faults

Common Faults.

Noted below are the most common Faults experienced.





'CSC15' Alarms.

There is an issue with the Unit, but it will still operate.

<u>Indication:</u>	<u>Description:</u>	<u>Most Common Items to Check:</u>
 <p>[Slow flash]</p>	Service Due	Service unit (please refer to Preventative Maintenance Schedule on pg. 13)

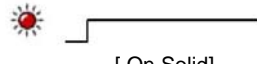
'CSC15' Shutdown Errors.

There is an issue with the Unit and the Unit will not operate until the Fault has been addressed.

<u>Indication:</u>	<u>Description:</u>	<u>Most Common Items to Check:</u>
 <p>[On Solid]</p>	Anti-Rotation	Rotation of Motor wrong, Solenoid Valve not relieving pressure, Intake Valve Orifice clogged
 <p>[Fast Flash]</p>	Power Interruption	Power failure occurred, power was interrupted before Unit completed its Stop Sequence
 <p>[Two Flashes]</p>	Excessive Temperature	Ambient temp high, Unit dirty, low oil level, no air flow through Cooler, Temperature Switch defective
 <p>[Three Flashes]</p>	Motor Overload	Motor drawing high amps, low voltage, higher pressure settings, low oil level, loose wires

Separator Filter and Refrigerated Air Dryer

Your Unit may be equipped with a Separator Filter and an 'ASD15' Refrigerated Air Dryer Unit as indicated below. These items are located in the compressed air lines after the air is compressed and after the Air Receiver.

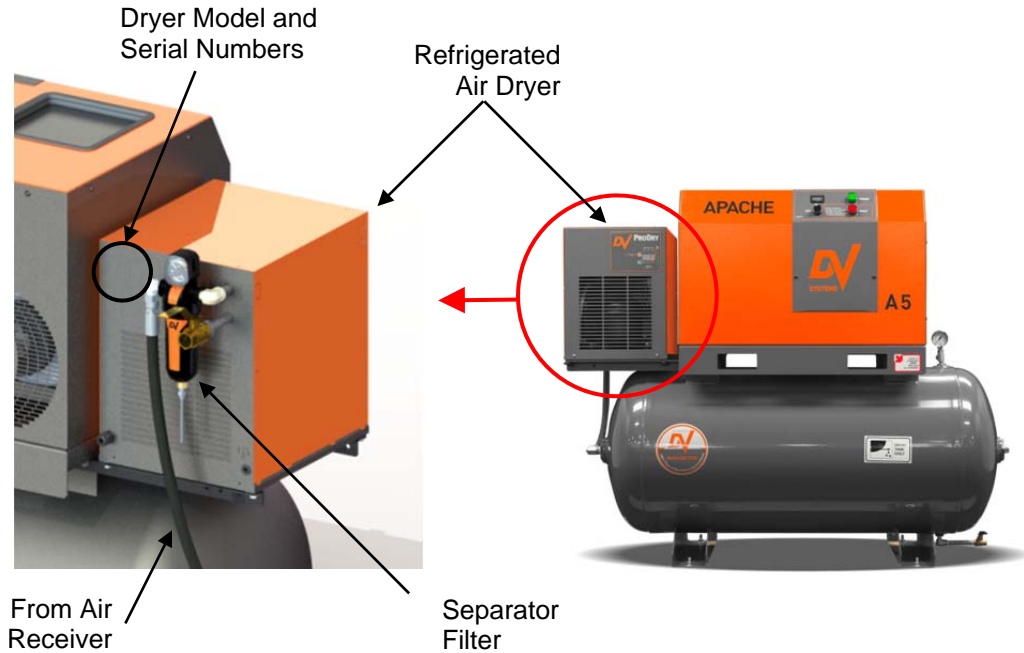

More detailed information concerning the Dryer Unit is included in the Dryer manual. The information contained in this manual is a 'quick reference' only.

Dryer Controls.

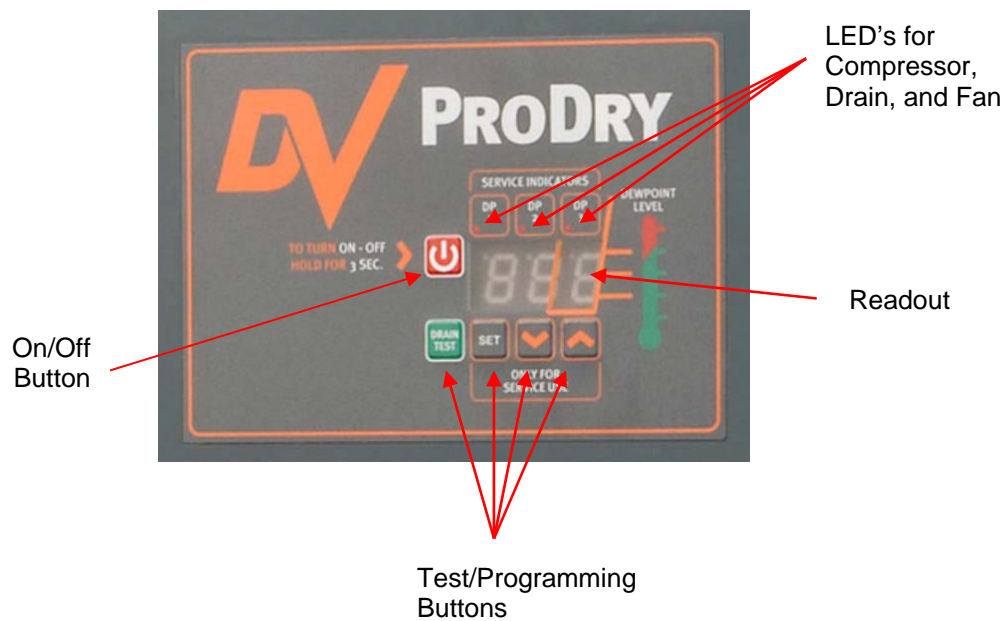

Separator Filter and Refrigerated Air Dryer (cont'd)

Typical Dryer Operation.

The Dryer will operate as follows:

- Pressing the 'On/Off' Button for 3 seconds will start the Unit
- There is a time delay of up to 2 minutes before the Refrigerant Compressor starts.
- The Condenser Fan will start approx. 30 seconds there-after.
- The Fan will not normally run at full speed, this indicated by a flashing LED
- The readout will initially show ambient temperature indicated by 3 horizontal bars on the readout
- Once the Fan and Compressor start, the dew point of the Unit will decrease to approx. 1°C, this indicated by 1 horizontal bar.
- Once at approx. 1°C, the Fan will stop, only to be called to run again once the temperature increases to approx. 5°C
- Pressing the 'On/Off' Button (when the Unit is operating) will run the Fan at full speed for several seconds, after which the Unit will stop. (The LED will be on continually while the Fan runs at full speed.)

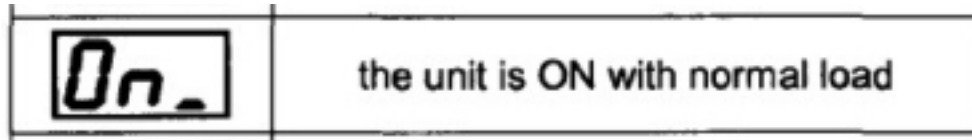

- As well as showing the dew point, the readout may indicate several fault codes as suggested below.

Typical Fault Codes.

The readout will indicate a variety of 'fault codes', the most common being as follows:

ESA

Energy Saving Mode.

- The Dew Point has been running at below -1°C for over 6 minutes.
- The Unit will automatically restart operation at 6°C.

PFI

Temperature Probe Alarm.

- The Temperature Probe is not working properly. It may not be connected to the Board, or the Probe may be defective.
- Replace the Probe if necessary.

HTA

High Temperature Alarm.

- The Dew Point has been running at above 12.5°C for over 6 minutes. The Unit must be manually turned off and on.
- The fault could be caused by a dirty radiator, high ambient temperature, a faulty Fan, or a faulty refrigerant Compressor, to name a few.

Separator Filter and Refrigerated Air Dryer (cont'd)

Typical Separator Filter.

As previously noted, the Separator Filter is located between the Air End and the Refrigerated Dryer. It contains a 1 micron Separator Element which protects the Dryer Unit by removing liquids and solid particles 1 micron and larger.

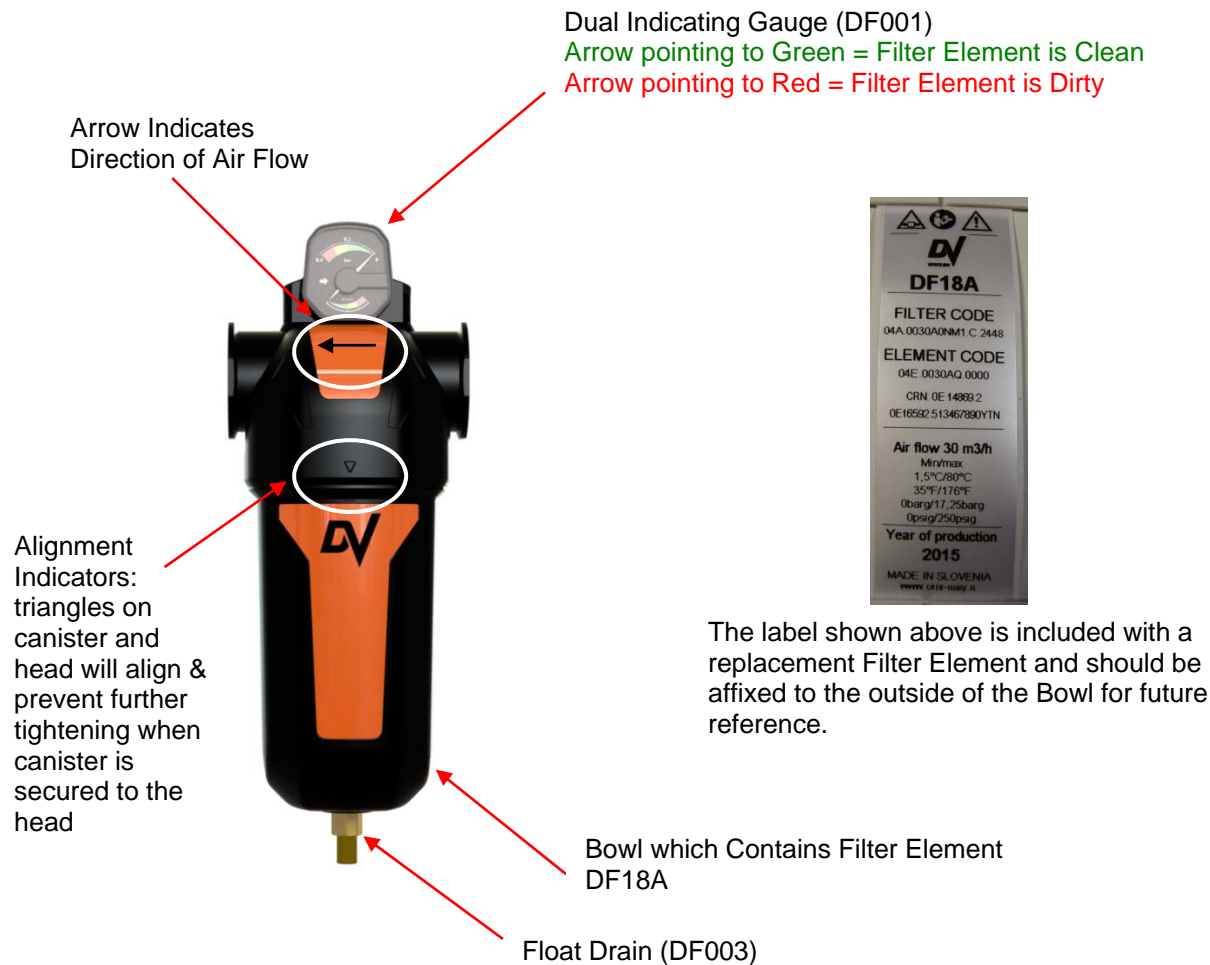

Filter Element Replacement.

To replace a dirty Filter Element:

- Shut the Compressor Unit off.
- Bleed any compressed air from the system to ensure there is no pressure at the Filter.
- Unscrew the Bowl from the assembly, exposing the dirty Filter Element.
- Pull the Filter Element out of the Canister Head
- Clean any debris from the inside of the Bowl
- Remove the O-ring from the inside of the Canister Head
- Install the new O-ring making sure it is properly seated
- Place the new 1 micron Separator Filter Element into the Bowl (the filter is self-centring).
- Screw the Canister with the Element inside it to the Canister Head until the indicators line up.
- Gauge will return to **green** when Filter is once again under pressure.

Troubleshooting Guide



When servicing the Air Compressor, shut off all power to the Unit, and drain it of air pressure.

The 'Conditions', 'Causes', and 'Suggested Corrections' as indicated below and on the following page(s) are only a guideline for troubleshooting that we have found to be most common.

Though this information is provided in this booklet, it is assumed and expected that any personnel involved in the servicing of an Air Compressor Unit is knowledgeable with this type of equipment. Do not attempt to service a Compressor Unit unless you are familiar with it, as there are many issues that may come into play, the most important being personal safety and the welfare of the Unit.

Should you have any questions, or require servicing to your Unit, please contact your local DV Systems Distributor/Service Center.

<u>Condition:</u>	<u>Cause:</u>	<u>Suggested Correction:</u>
A. Unit won't start.	No power to the Unit. Loose and/or missing wires in the electrical circuit. Motor Overload is tripped. Compressor over-heated and stopped. Unit shut off because pressure is not below 110 psi. Automatic Idle Time stopped the Unit. Power interruption.	Check that power at the disconnect or breaker is on. Also, check primary and secondary fuses inside the control box. Check that all wiring connections are tight. With a wiring schematic, check that all wiring is present and correct. Reset the overload inside the Control Panel. Insufficient air flow to cool Unit. Ambient temperature too high. Heat Exchanger is dirty. Faulty Temperature Switch. Oil level is low. Drop pressure below 110 psi. Drop the pressure below 110 psi. Reset the Unit.



Trouble Shooting Guide (cont'd)

<u>Condition:</u>	<u>Cause:</u>	<u>Suggested Correction:</u>
B. No or Insufficient Air Flow.	Air Filter is dirty. Oil Separator is blocked. Intake Valve is faulty. Air leaks in the system. Pressure limits are incorrectly set. Blowdown Solenoid Valve is open. Belt is broken.	Replace the Air Filter. Replace the Oil Separator. Repair or replace the Intake Valve. Check the Unit and system for air leaks. Adjust the pressure settings. Check the wiring to the Solenoid and replace as necessary. Check Belt tension and that Belt is in good condition.
C. Unit is overheating.	Ambient temperature is too high. Blocked air circulation at the Unit. Heat Exchanger is dirty. Oil level is too low. Using wrong type of compressor oil. Thermo Valve is faulty. Oil Filter is blocked. Temperature Sensor is faulty. Cabinet door/panel is open/off.	Check cooling air circulation. Check the air circulation in and around the Unit. Clean the Heat Exchanger Add oil as required. Change to the factory recommended oil. Check and repair as necessary. Replace the Oil Filter. Check the wiring to the Temperature sensor. Replace the Sensor if necessary. Secure the door/panel to the Unit.
D. Compressor Starts Slowly.	Intake Valve Seal is closed. Ambient temperature is too low. Minimum Pressure Valve leaking back to Air End. Minimum Pressure Valve setting is too high. Using wrong type of oil.	Intake Valve is seized. Repair or replace. Stop and restart once ambient increases. Repair or replace the Minimum Pressure Valve. Adjust Minimum Pressure Valve setting to 65 psi. Change to factory recommended oil.
E. Intake Valve Leaks Oil When Unit Stops.	Intake Valve Seal leaks. Intake Valve stuck in open position. Blowdown Solenoid not functioning.	Repair using an Intake Valve Repair Kit. Repair or replace the Intake Valve. Replace the Solenoid.



Trouble Shooting Guide (cont'd)

<u>Condition:</u>	<u>Cause:</u>	<u>Suggested Correction:</u>
F. Oil Consumption is Too High.	Oil level is too high. Oil Return Line (Scavenge Line) is blocked. Oil Separator is saturated with oil. Wrong type of oil used. Unit load is light or excessive load/idle cycles.	Reduce the oil level to the proper level. Clean and/or replace the Scavenge Line Sight Glass. Replace the Oil Separator. Change to factory recommended oil. Ensure Unit is set to operate at correct pressures, and there is a <u>minimum</u> of 20 psi differential. Also the Unit could be oversized for the tank capacity.
G. Compressor Surges.	Restriction in Hoses. Pressure Switch setting is incorrect or malfunctioning. Blockage at Unit outlet.	Flush out or replace. Set pressure as per instructions or replace. Check for obstructions in outlet piping.
H. High Power Consumption.	Improper air pressure settings. Blowdown Solenoid is not functioning. The voltage in the building is too low or there is a phase imbalance. The Motor is failing.	Reset the pressure as per factory defaults. Inspect or replace as necessary. Contact an Electrician to verify. Have Motor inspected.
I Fault Alarms.	Red Light On Solid: Anti-Rotation Red Light Fast Flash: Power Interruption Red Light Two Flashes: Service Due Red Light Three Flashes: Overload Fault	See 'Page 14'.



Limited Warranty : A5 Series Screw Compressors

The manufacturer warrants the product manufactured by it and sold to the original purchaser, when properly installed, operated, applied, and maintained in accordance with procedures and recommendations outlined in the manufacturer's instruction manuals, to be free of defects in material and workmanship for a period of one (1) year from the date of installation, not to exceed eighteen (18) months from the date of manufacture, provided such defect is discovered and brought to the manufacturer's attention within the aforesaid warranty period, conditional upon the following:

- 1) Genuine 'DEV-3000' Lubricant and Parts are used for the full warranty period.
- 2) The Unit is maintained in accordance with the manufacturer's instruction manual for the Unit, with the following minimum maintenance requirements:
 - A) Complete Oil change every 8000 hours (not to exceed 12 months) from the date of initial start-up using 'DEV-3000' Lubricant. When operating in adverse conditions, Oil changes must be done more frequently.
 - B) Oil Filter must be changed every 4000 hours (not to exceed 12 months) from the date of initial start-up using the appropriate DV Systems part. When operating in adverse conditions, Oil Filter changes must be done more frequently.
 - C) Air Intake Filter must be changed every 2000 hours (not to exceed 6 months) from the initial date of start-up using the appropriate DV Systems part. When operating in adverse conditions, Air Intake Filter changes must be done more frequently.
 - D) Air/Oil Separator Filter must be changed every 8000 hours (not to exceed 12 months) from the date of initial start-up using the appropriate DV Systems part. When operating in adverse conditions, Air/Oil Separator changes must be done more frequently.
 - E) Appropriate and complete maintenance records must be kept by the End User. As well, the End User must retain copies of invoices indicating the timely purchase of the DV Systems Compressor Oil and maintenance/service parts. All records and invoices must be kept for the duration of the manufacturer's warranty period.
- 3) Disclaimer:
 - A) The following items are considered normal wear items, and are warranted for a period of one (1) year from the date of installation, not to exceed eighteen (18) months from the date of manufacture; the Shaft Seal on the Air End Drive Shaft, the Intake Valve Assembly (and its components), and the Minimum Pressure Valve.
 - B) All electrical components are warranted for a period of one (1) year from the date of installation, not to exceed eighteen (18) months from the date of manufacture.

An additional four (4) year extended Air End & Cooler Warranty is available on those Units that:

- A) have been registered with the manufacturer within thirty (30) days from the date of purchase, this done by returning the 'DV Systems Rotary Screw Compressor Start-Up Sheet' or registering the unit at dvcompressors.com and
- B) have been maintained in accordance with the manufacturer's instruction manual as noted in '2' above.

The manufacturer will repair or replace any product or part determined to be defective by the manufacturer within the warranty period, provided such defect occurred in normal service and is not the result of misapplication, misuse, abuse, neglect, incorrect maintenance, accident, or normal wear. Normal maintenance items requiring routine replacement are not warranted. Please refer to the appropriate service bulletin to determine normal maintenance requirements.

The warranty covers parts and labour for the warranty period. Either repair or replacement shall be at the sole option of the manufacturer. Any service performed on the product by anyone other than the manufacturer must first be authorized by the manufacturer. Unauthorized service voids the warranty and any resulting charge or subsequent claim will not be paid.

Products repaired or replaced under warranty shall be warranted for the unexpired portion of the warranty applying to the original product, based on the original date of invoice as outlined above.

There is no other expressed warranty. Implied warranties including those of merchantability and fitness for a particular purpose are limited to one (1) year from the date of invoice to the extent permitted by law and any and all implied warranties are excluded. This is the exclusive remedy. Liability for consequential damages under any and all warranties are excluded to the extent exclusion is permitted by law.

This warranty gives you specific rights, and you may also have other rights within your jurisdiction.

This warranty does not cover:

- 1) Merchandise that has become inoperative because of ordinary wear, misuse, neglect, accident, or improper and unauthorized repair or alteration.
- 2) Electric Motors manufactured and identified as the product of another company.
- 3) Compressor Units that have not been properly maintained in accordance with the recommended maintenance and lubrication change procedures and/or that have been subject to inordinate use through being inadequately sized or poorly installed.
- 4) Compressor Units using other than the recommended lubricant.
- 5) Costs occasioned by the removal, replacement, or repair of merchandise (other than by DV Systems) without previous authorization from DV Systems.
- 6) Expenses incurred in travel or lodging beyond a 100 kilometre (60 mile) distance from the nearest DV Systems Authorized Service Centre.
- 7) Expenses incurred in the return of equipment for inspection purposes to the manufacturer's facility. All returns must be pre-authorized, returned 'Freight Prepaid', and accompanied by a 'Return Material Authorization (RMA) Number' (obtainable through DV Systems).
- 8) Products, parts, materials, components, or accessories manufactured by others or supplied in connection with the sale of the manufacturer's products.
- 9) Repair and transportation costs of merchandise determined not to be defective under the terms and conditions of this warranty.
- 10) The cost of rental or loaner equipment while the customer's original equipment is being assessed, repaired, or replaced.
- 11) Consequential damages in the event of product failure.

All decisions by DV Systems, Inc. with regard to this policy shall be final. DV Systems will not be responsible for any claimed defective materials returned other than in accordance with this statement of policy or without our prior authorization.

DV Systems, Inc. (Canada)
490 Welham Road
Barrie, Ontario, L4N 8Z4, Canada
Tel: (705) 728-5657
Fax: (705) 728-4974

DV Systems, Ltd. (USA)
128-B Talbert Road
Mooresville, NC, 28117, USA
Tel: (704) 799-0046
Fax: (704) 799-0355